

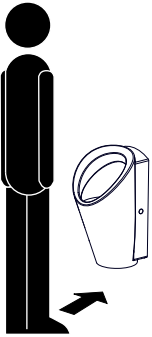
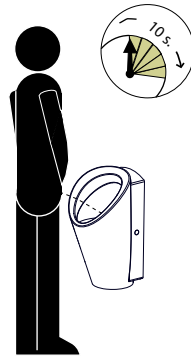
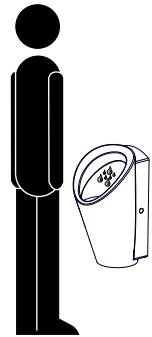
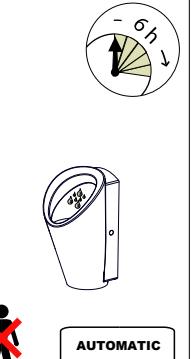
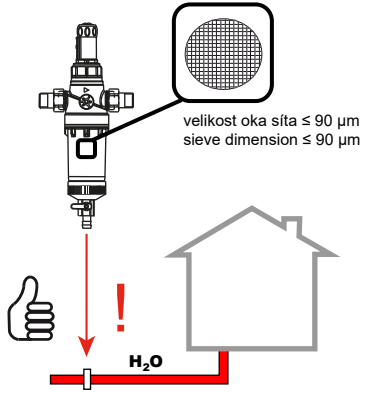

Pisoár Lema s radarovým splachovačom a integrovaným zdrojom, 230V AC
Urinal Lema with a radar flushing unit and integrated power supply, 230V AC

CZ Návod na použití	RU Инструкция по эксплуатации	RO Instrucțiuni de utilizare	NL Gebruiksaanwijzing
SK Návod na použitie	D/A Gebrauchsanleitung	ES Instrucciones de uso	LT Naudojimosi instrukcija
GB Instructions for use	PL Instrukcja użytkowania	FR Mode d'emploi	

CZ STANDARDNÍ funkce	RU СТАНДАРТНАЯ программа	RO Funcționare în regim STANDARD	NL Standaard functies
SK Funkcia	D/A Funktion	ES Función estándar	LT STANDARTINĖ programa
GB Function	PL Funkcja	FR Fonction	

<p>1. </p>	<p>2. </p> <p>min. 10 s.</p>	<p>3. </p>	<p>4. </p> <p>6 h / SLD 04 (6, 24, 48, 72)</p>	 <p>velikost oka sítá ≤ 90 μm sieve dimension ≤ 90 μm</p> <p>H₂O</p>
---	---	---	--	--

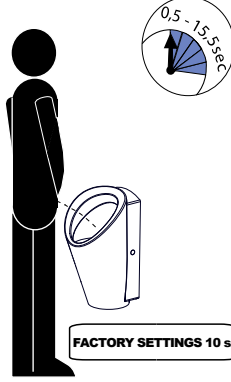
<ul style="list-style-type: none"> CZ Aktivační čas SK Aktivačný čas GB Using time RU время использования D/A Der Zeit nutzen PL Czas aktywacji RO Timp de utilizare ES Tiempo de activación FR temps d'utilisation NL Tijd gebruik LT naudojimosi trukmė 	 <p>FACTORY SETTINGS 10 s.</p>	<p>10 s. (SLD 04: 0,5 - 15,5 s.)</p>
---	--	--------------------------------------

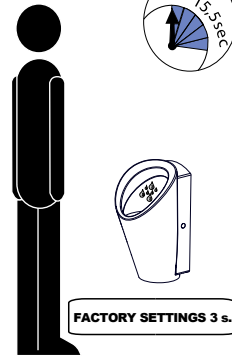
<ul style="list-style-type: none"> CZ Čas splachování SK Čas splachovanie GB Flushing time RU продолжительность смыва D/A Wasserlaufzeit PL Czas spłukiwania RO Timp de spălare ES Tiempo de enjuagar FR temps de rinçage NL Spoeltijd LT vandens nuleidimo trukmė 	 <p>FACTORY SETTINGS 3 s.</p>	<p>3 s. (SLD 04: 0,5 - 15,5 s.)</p>
--	--	-------------------------------------

CZ Montážní návod	RU Инструкция по монтажу	RO Instrucțiuni de montaj	NL Montage instructie
SK Montážny návod	D/A Montageanleitung	ES Manual de instrucciones	LT Montavimo instrukcija
GB Mounting instructions	PL Instrukcja montażu	FR Notice de montage	

CZ Specifikace dodávky	RU Спецификация поставки	RO Componente livrate	NL Leveringsomvang
SK Špecifikácia dodávky	D/A Lieferumfang	ES Especificación de suministro	LT Tiekimo specifikacija
GB Supplied equipment	PL Specyfikacja dostawy	FR Equipements fournis	

SLP 59RZ - Obj. č. (Code Nr.) - 01595

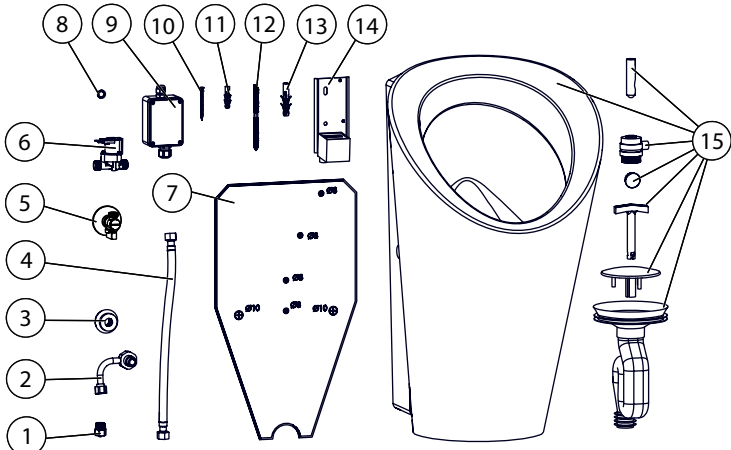
	<table border="1"> <thead> <tr> <th>Pozice / Position</th> <th>Obj. číslo / Order num.</th> <th>Počet / Quantity</th> </tr> </thead> <tbody> <tr><td>1</td><td>46480</td><td>1</td></tr> <tr><td>2</td><td>44796</td><td>1</td></tr> <tr><td>3</td><td>44737</td><td>1</td></tr> <tr><td>4</td><td>45995</td><td>1</td></tr> <tr><td>5</td><td>45940</td><td>1</td></tr> <tr><td>6</td><td>45936</td><td>1</td></tr> <tr><td>7</td><td>46497</td><td>1</td></tr> <tr><td>8</td><td>45572</td><td>1</td></tr> <tr><td>9</td><td>05060</td><td>1</td></tr> <tr><td>10</td><td>45845</td><td>4</td></tr> <tr><td>11</td><td>45782</td><td>4</td></tr> <tr><td>12</td><td>46653</td><td>2</td></tr> <tr><td>13</td><td>46652</td><td>2</td></tr> <tr><td>14</td><td>46453</td><td>1</td></tr> <tr><td>15</td><td>46269</td><td>1</td></tr> </tbody> </table>	Pozice / Position	Obj. číslo / Order num.	Počet / Quantity	1	46480	1	2	44796	1	3	44737	1	4	45995	1	5	45940	1	6	45936	1	7	46497	1	8	45572	1	9	05060	1	10	45845	4	11	45782	4	12	46653	2	13	46652	2	14	46453	1	15	46269	1
Pozice / Position	Obj. číslo / Order num.	Počet / Quantity																																															
1	46480	1																																															
2	44796	1																																															
3	44737	1																																															
4	45995	1																																															
5	45940	1																																															
6	45936	1																																															
7	46497	1																																															
8	45572	1																																															
9	05060	1																																															
10	45845	4																																															
11	45782	4																																															
12	46653	2																																															
13	46652	2																																															
14	46453	1																																															
15	46269	1																																															

(CZ) Instalace
 (SK) Inštalácia
 (GB) Installation

(RU) Схема включения и монтажа
 (D/A) Installation
 (PL) Instalacja

(RO) Instalare
 (ES) Instalación
 (FR) Installation

(NL) Installatie
 (LT) Montavimo ir įjungimo schema

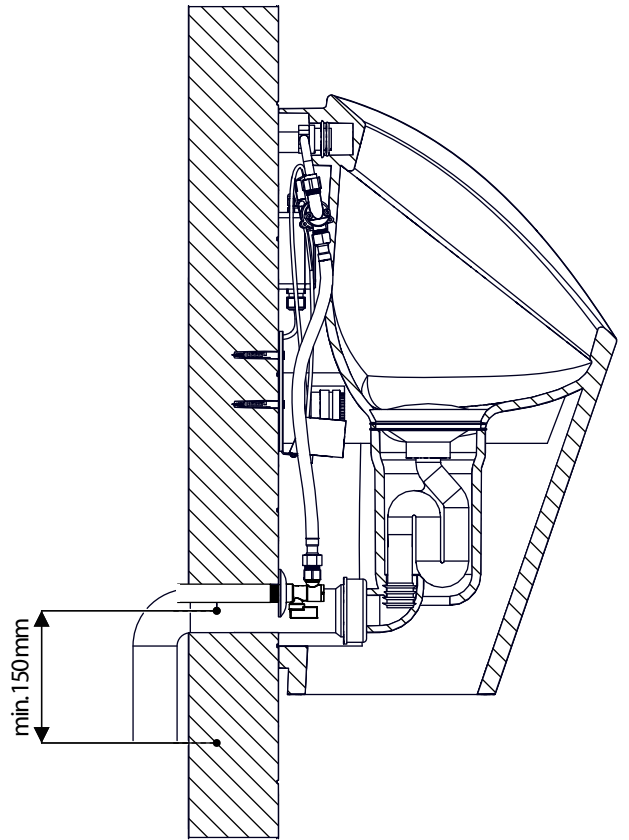
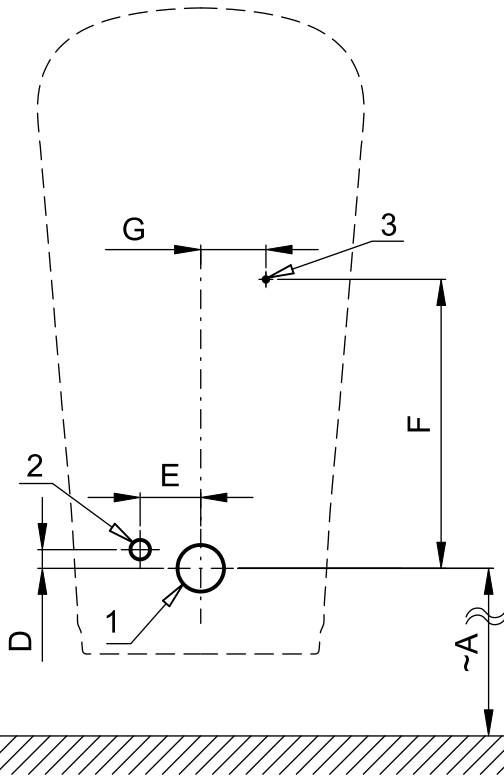

KÓTY [mm]	A	B	C	D	E	F	G	H	I	J	K	L
DIMENSIONS [mm]	350			20	65	310	70					

CZ

- 1 - odpadní potrubí Ø 50 mm
- 2 - vstup vody do pisoáru
- 3 - napájecí kabel 230V AC

GB

- 1 - waste pipeline Ø 50 mm
- 2 - water supply
- 3 - power supply 230V AC

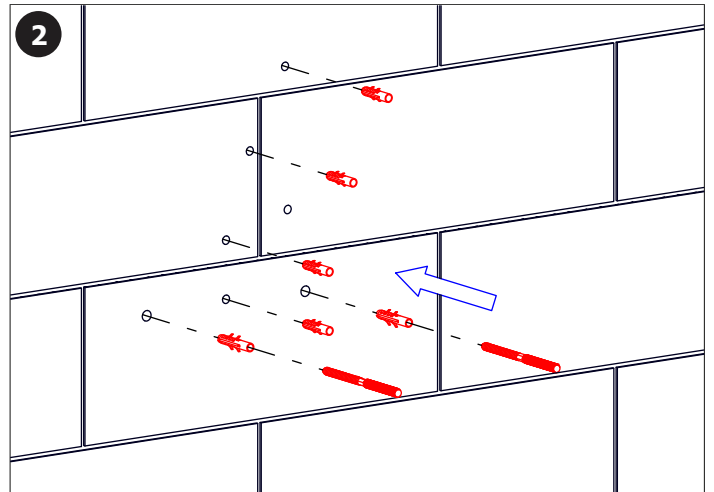
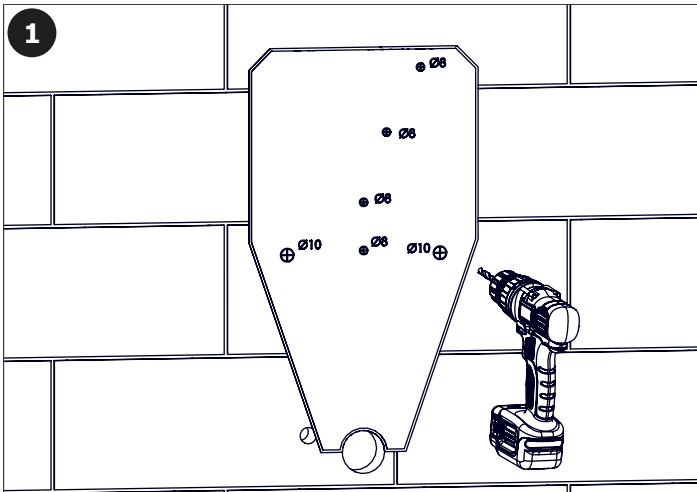

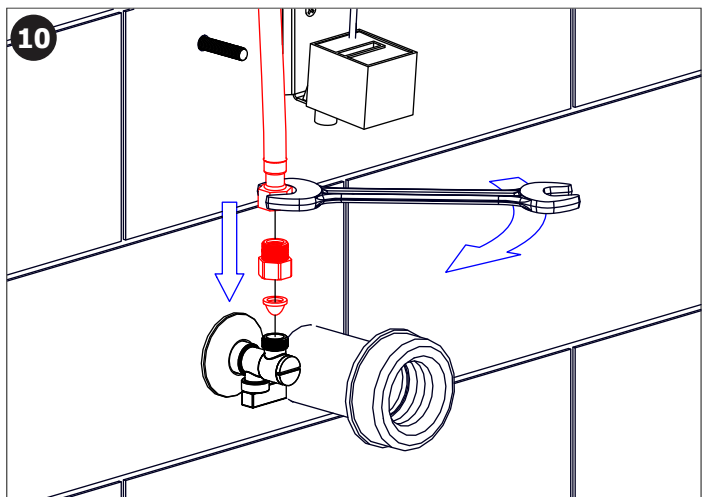
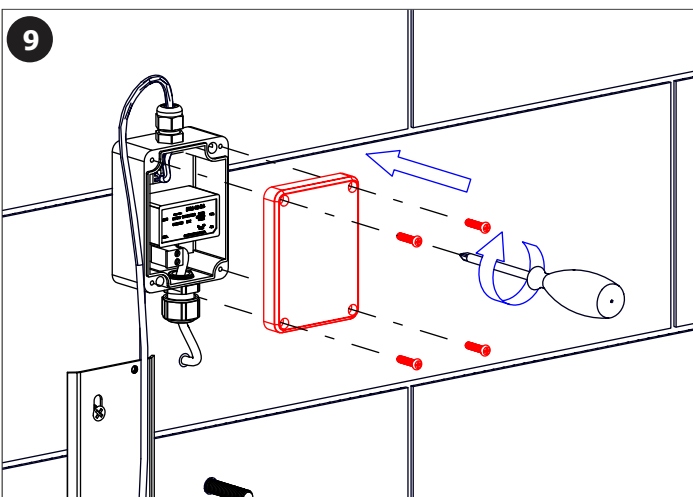
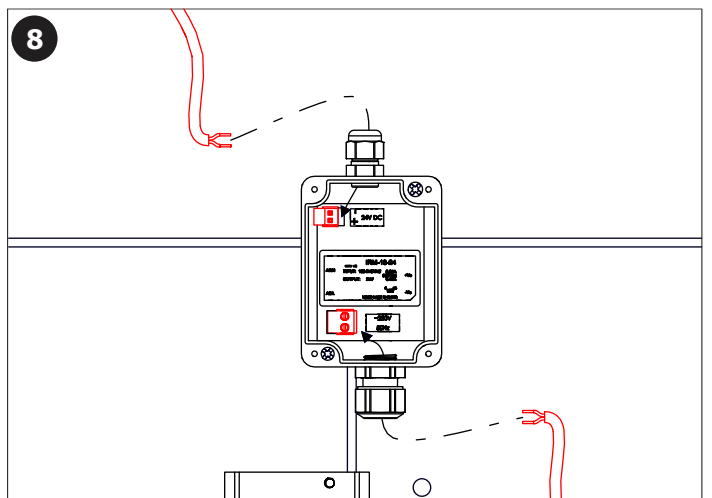
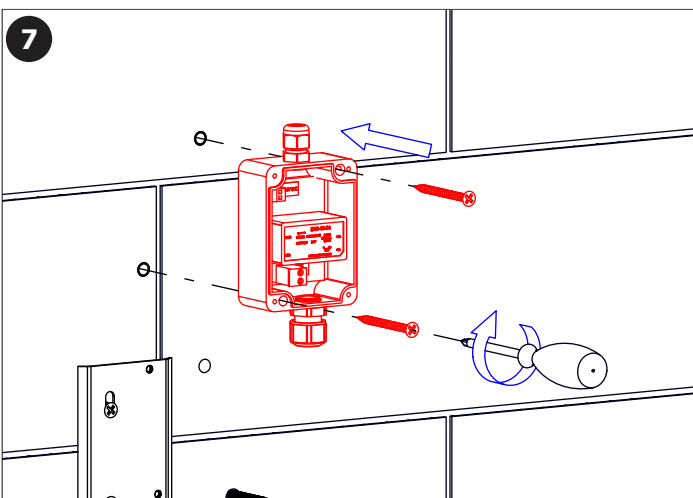
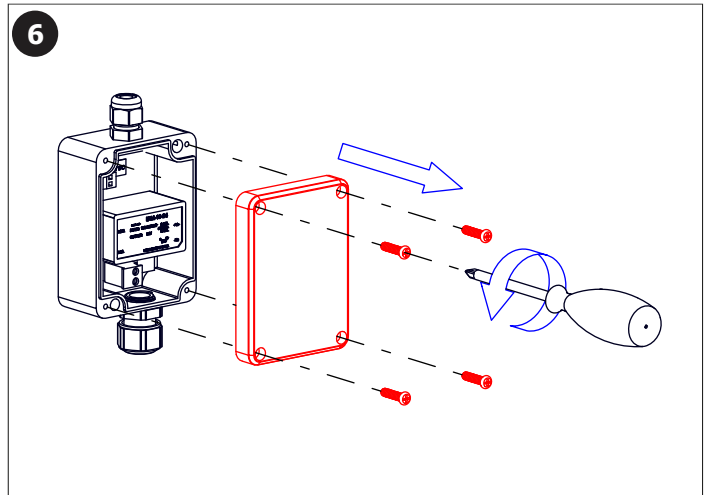
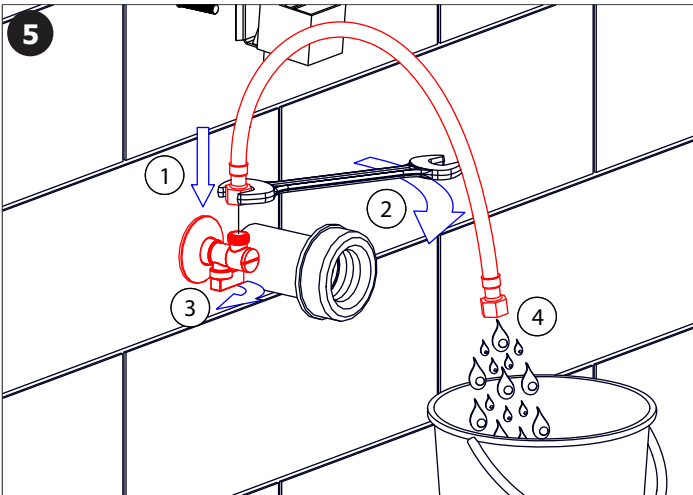
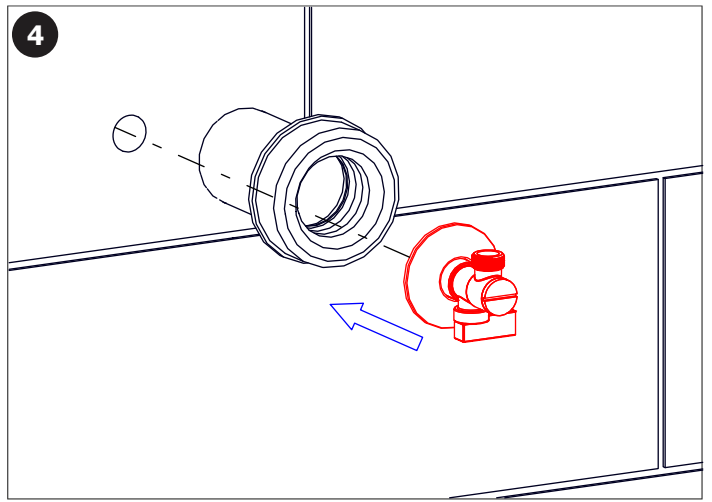
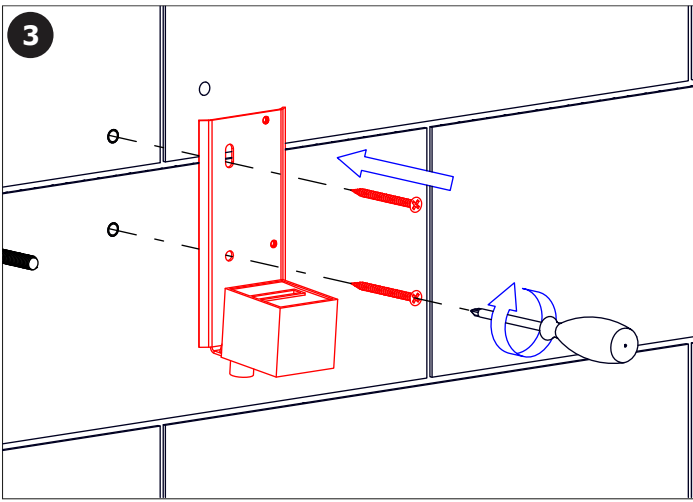

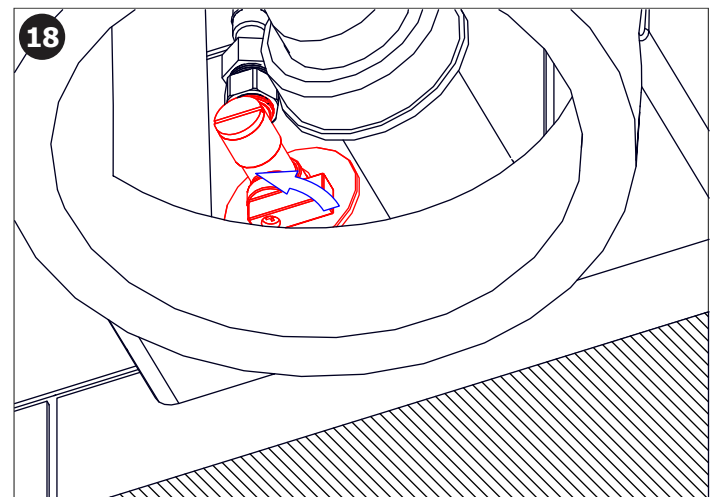
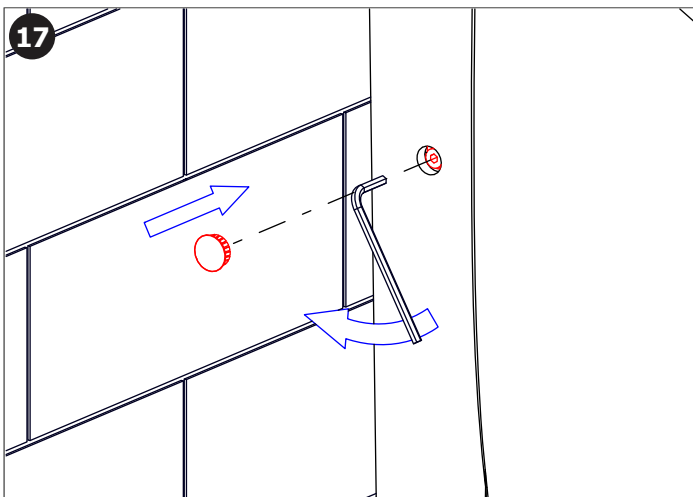
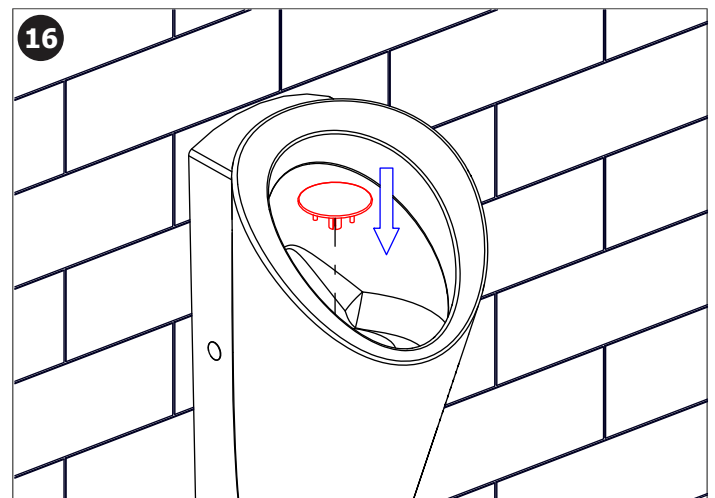
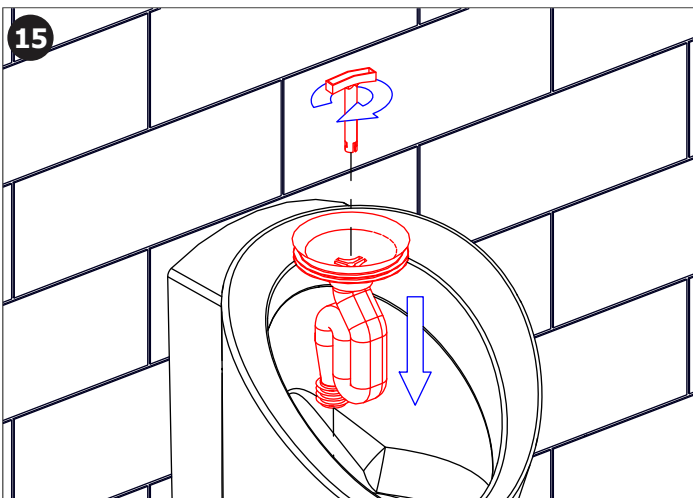
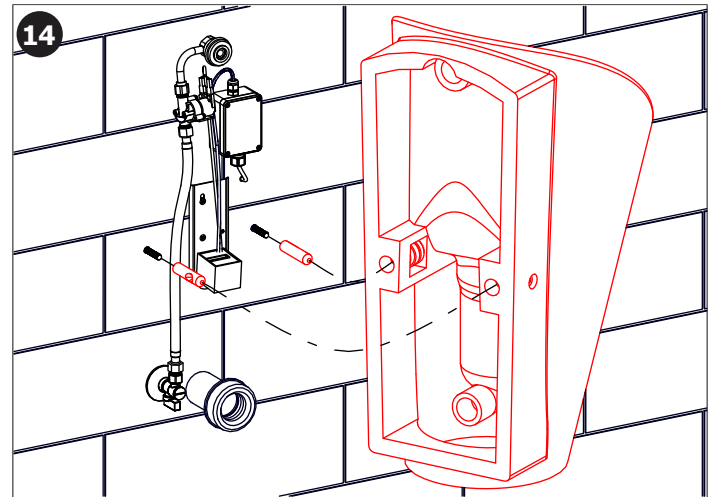
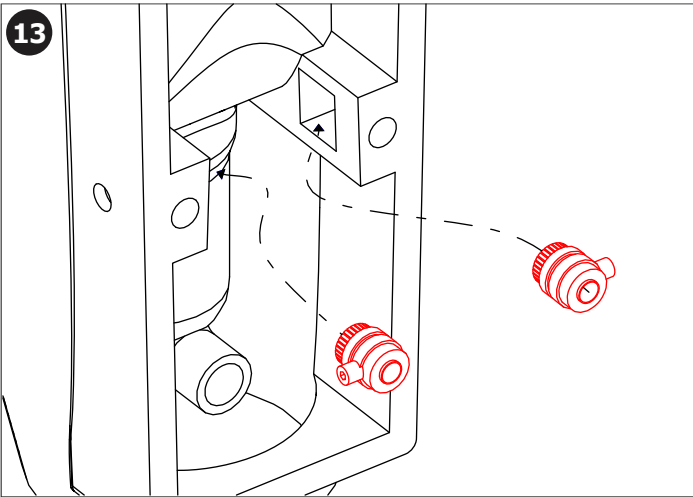
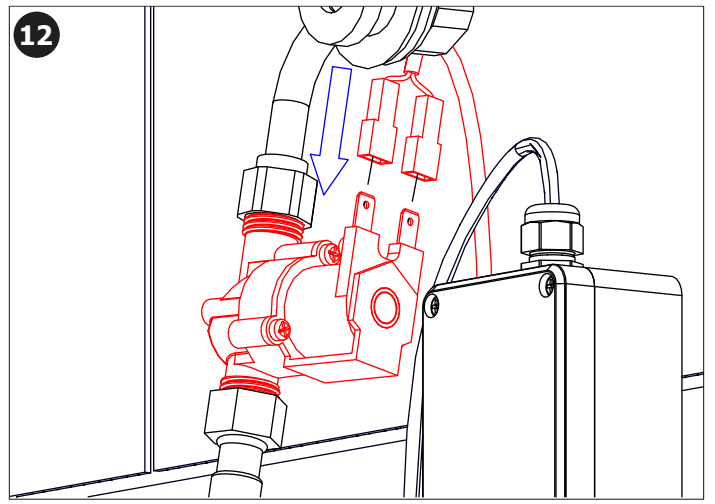
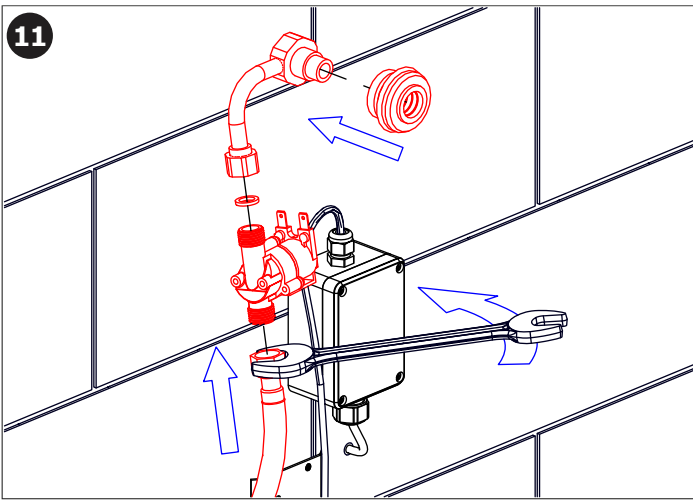

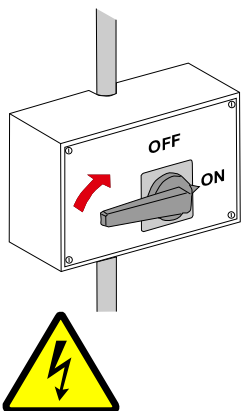

19

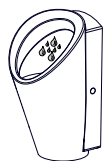
- CZ** Pro správnou funkci musí být výrobek trvale pod napětím (nepřipojovat napájecí zdroj za vypínač světelného okruhu)!
- SK** Pre správnu funkciu musí byť výrobok trvale pod napätím (nepripojuvať napájací zdroj za vypínač svetelného okruhu)!
- GB** It is necessary, for the proper function, to keep the unit under constant voltage (don't connect the power supply unit behind the switch into the light circuit)!
- RU** Для бесперебойной работы, изделие должно быть постоянно под напряжением (нельзя подключать источник питания за выключателем световой цепи)!
- DA** Für die richtige Funktion ist es erforderlich, die Einheit unter konstanter Spannung zu halten (den Anschluss des Transformators nicht nach dem Schalter in einem Lichtstromkreis anschliessen)!
- PL** Dla prawidłowego działania urządzenia potrzebne jest stałe zasilanie (nie podłączać zasilania urządzenia pod czujnik ruchu)!
- RO** Pentru o funcționare corespunzătoare unitatea trebuie să fie sub tensiune în mod constant (nu conectați transformatorul după întrerupătorul de la sistemul de iluminat)!
- ES** ¡Para el funcionamiento correcto del producto debe estar sometido a tensión permanente (no conecte la fuente de alimentación del interruptor de trás del circuito de iluminación)!
- FR** Pour le bon fonctionnement il est nécessaire de maintenir l'unité sous tension constante (ne pas connecter l'alimentation derrière un interrupteur)!
- NL** Voor een goede functionaliteit is het noodzakelijk om de unit onder continue spanning te houden (niet de voeding aansluiten achter de knop van het licht-circuit)!
- LT** Kad tinkamai veiktų yra būtina užtikrinti, kad vienetas būtų nuolatiniėje įtampoje (neprijunginkite maitinimo šaltinio prie šviesos grandinės jungiklio)!

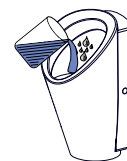
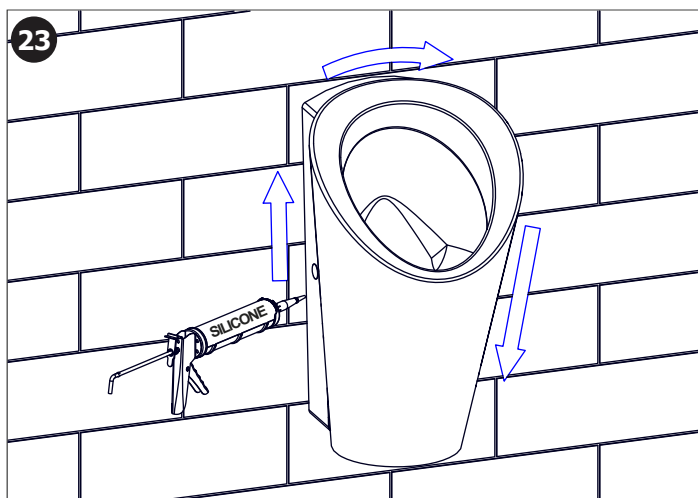
20**AUTOMATIC ADJUSTMENT****1x** 1 min. **21****ADJUSTMENT MODE****22****TEST**
min. 10 s.**23**

CZ

Vzhľadom k možnosti zanesení ventilu nečistotami z vody je doporučeno provést 1x ročně kontrolu sítka elektromagnetického ventilu, dotažení šroubových spojů a dosadacích ploch konektorů.

Po vybalení výrobku je nutné s obalem postupovat podle zákona o obalech.

Výrobce ujišťuje, že na výrobek je vydáno prohlášení o shodě v souladu se zákonem č. 22/1997 Sb.

SK

Vzhľadom k možnosti zanesenia ventilu nečistotami z vody sa doporučuje previesť 1x ročne kontrolu sítka elektromagnetického ventilu, dotiahnutia skrutkových spojov a dosadacích plôch konektorov.

Po vybalení výrobku je potrebné s obalom postupovať podľa zákona o obaloch.

Výrobca garantuje, že na výrobok je vydávané prehlásenie o shode v súlade so zákonom č. 22/1997 Sb.

GB

It is recommend to check up the sifter of electromagnetic valve once a year, because of there is a possibility that valve could be fouled up. Checking of tightening of screw connections and connectors contact surfaces is also recommend once a year.

It is necessary to proceed according to the law about packaging material after unpacking of the product.

Producer assures that this product has declaration of conforminty in accordance with the regulation 73/023/EEC and 89/336/EEC.

RU

Учитывая возможность засорения вентиля грязью, приносимой водой, рекомендуется 1 раз в году выполнить контроль состояния сетки электромагнитного вентиля, затянуть резьбовые соединения и зажимы коньекторов.

Утилизация упаковочного материала должна производиться в соответствии с законом.

Производитель подтверждает, что у этого изделия есть Декларация Соответствия в соответствии с нормами 73/023/EEC и 89/336/EEC.

D / A

Wegen der Möglichkeit, daß Ventil mit Schmutz vom Wasser verstopft kann sein, wird empfohlen, 1-mal pro Jahr Kontrolle des Siebes des elektromagnetischen Ventils, Nachziehung der Schraubverbindungen und Aufsitzflächen der Anschlüsse durchführen.

Dies ist erforderlich auf der Grundlage der gesetzlichen Bestimmungen für die Rücknahme und/oder Entsorgung von Verpackungsmaterial.

Wir, SANELA spol. s r.o. erklären dass dieser Product ist in Übereinstimmung mit die nächste Norm: 73/023/EEC und 89/336/EEC.

PL

Ze względu na zanieczyszczenia znajdujące się w wodzie zaleca się przynajmniej 1x do roku przeprowadzić kontrolę stanu sítka w elektrozaworze, dokręcić śrubki na obudowie elektrozaworu i sprawdzić podłączenie konektorów.

Po wypakowaniu urządzenia zaleca się postępować zgodnie z instrukcją obsługi.

Producent posiada na swoje wyroby deklaracje zgodności na podstawie przepisu c.73/023/EEC i 89/336/EEC.

RO

Recomandăm curățirea fitrelor și a electrovalvei cel puțin o dată pe an, impuritățile din apă pot bloca electrovalva. Este recomandată și verificarea conexiunilor electrice, curățirea contactelor și strângerea șuruburilor.

Gestionarea ambalajelor se va realiza conform legislației în vigoare.

Producătorul garantează că aceste produse au declarații de conformitate care respectă reglementările 73/023/EEC și 89/336/EEC.

ES

Dada la posibilidad de obstrucción de la válvula por las impurezas del agua se recomienda llevar a cabo el control anual (una vez por año) del cedazo de la válvula de solenoide, el apretado de las conexiones de tornillo y las superficies del apoyo del conector.

Después de desembalar el producto es necesario proceder con el embalaje en acuerdo con la ley de los embalajes.

El productor asegura que este producto tiene declaración de conformidad de acuerdo con la ley núm. 73/023/EEC y 89/336/EEC.

FR

Il est recommandé de vérifier le tamis de l'électrovanne une fois par an, afin de vérifier que la membrane ne soit pas encrassée. La vérification du serrage des vis et des surfaces de contact des connecteurs est également recommandé une fois par an.

Conformément à la loi, Il est nécessaire de se conformer à la procédure de déballage du produit.

Le fabricant garantie que ce produit est en conformité avec la réglementation 73/023/EEC et 89/336/EEC.

NL

Het wordt aanbevolen om minimaal 1 x per jaar de bewegende delen van de kleppen te controleren en indien nodig schoon te maken. Ook is het verstandig om aansluiting en schroeven te controleren of deze nog vast zitten.

Het is verplicht om de wet in acht te nemen betreffende het omgaan met verpakkingsmateriaal.

De producten worden geleverd met een verklaring van overeenstemming met 73/023/EEC en 89/336/EEC.

LT

Kadangi ventilis gali užsiteršti vandenyje esančiais nešvarumais, patariame kartą per metus išvalyti elektromagnetinį ventilių, patikrinti varžtelių įveržimą ir nuosėdas ant jungčių.

Išpakavus produktą būtina laikytis taisyklių atsižvelgiant į medžiagą, iš kurios pagaminta pakuotė.

Gamintojas garantuoja, kad šis produktas turi atitikties deklaraciją pagal reglamentą 73/023/EEC ir 89/336/EEC.

Doporučené příslušenství

CZ

SLD 04 dálkové ovládání pro nastavení radarových splachovačů a piezo ovládání

SLR 01L rám určený do sádrokartonových konstrukcí pro pisoár s radarovým splachovačem na liště

SLR 22 rám určený do sádrokartonových konstrukcí nebo pro ukotvení na zem a do zadní zdi, pro zabudování suchým procesem, pro uchycení pisoáru se senzorem umístěným nad pisoárem

SLA 19 sada náhradních náplní 12-ti ks

Recommended accessories

GB

SLD 04 remote control for setting of radar flushing units and piezo controls

SLR 01L mounting frame to the plasterboard for a urinal with a radar flushing unit on the mounting rail

SLR 22 mounting frame for urinal destined for a plasterboard constructions

SLA 19 set (12 pcs.) of Fresh Air spare fillings